

MYCOM

PROCESS COMPRESSORS

MAYEKAWA

MYCOM

SCREW COMPRESSORS

Mayekawa's history began almost a century ago when the company was founded in 1924. Since then, through a true partnership with its customers, Mayekawa has built a compressor brand "MYCOM" that is internationally recognized today. Mayekawa's oil flooded screw compressors, production of which began in 1964, have received high acclaim for their technological strength and reliability. They are renowned globally not only in the food, beverage and cold storages in distribution centers, but also in the oil & gas and chemical markets for gas compression and refrigeration applications where extreme durability is required of critical equipment. Mayekawa is also an industry leader in customer satisfaction. They deliver quality local customer support from more than 100 locations worldwide.

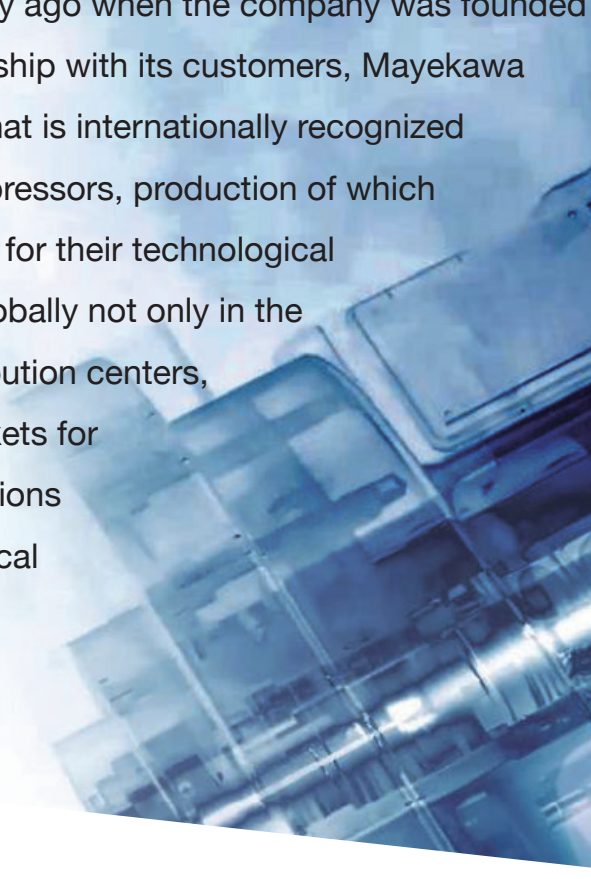

PROVEN GAS COMPRESSION TECHNOLOGY

Mayekawa's industry leading technology has enabled gas compression for virtually all kinds of gases under various conditions. It has broadened the range of applications of MYCOM compressors:

- Hydrocarbon gases -C_mH_n (VOC vapor recovery, wellhead gas gathering, etc.)
- Gases containing corrosive components like sour gas, flare gas, or coke oven gas
- Raw material gases such as vinyl chloride, monomer and methyl chloride, etc.
- Corrosive gases such as chloride, hydrogen chloride, hydrogen sulfide, C₂F₄, etc.
- Fuel gases such as natural gas, coal seam gas, liquefied petroleum gas, etc.
- Industrial gases such as helium, hydrogen, carbon dioxide, air, etc.
- Natural refrigerants such as propane, propylene, butane, pentane, ammonia, etc.
- Synthetic refrigerants including HFC, HCFC.



COMPRESSION MECHANISM

Compression is achieved by successive volume reduction of the space enclosed between the meshing line by the rotation of the male / female rotors and the casing.

During the suction phase, the gas enters the compressor rotors via the suction port and is sealed between the rotors and the casing.

As the rotors continue to rotate, the meshing line of the lobes moves toward the discharge end of the casing and the trapped volume gradually decreases, resulting in gas compression.

At the moment when compression reaches the designated ratio, this trapped volume becomes exposed to the discharge port and exits as a compressed gas.

These phases are continuously performed.

DURABILITY / RELIABILITY / MAINTAINABILITY

Compared to a conventional reciprocating compressor, a screw compressor has no consumable or fragile parts like suction/discharge valves, piston rings, etc.

The main friction-bearing parts are limited to journal bearings, thrust bearings, shaft seals and the fully lubricated intermeshing rotors, therefore the construction of the compressors is extremely simple and robust. The rotors are also constructed with high strength materials and can withstand slightly wet gases containing mist or liquid where reciprocating or centrifugal compressors may have serious problems. Even under the most severe operating conditions, the screw compressor demonstrates very high reliability. Fewer parts mean less maintenance work, and superior operational lifespan is achieved.

MYCOM

SCREW COMPRESSORS

CAPACITY CONTROL

Built-in unloader slide valve function enables the compressor capacity to be continuously adjusted from 10%* to 100%. Therefore, the compressor is able to run with appropriate load across a wide range of operating conditions, resulting in high efficiency operation. Capacity control through the use of bypass control valves or by variable speed inverter can be used in conjunction with the slide valve as well, depending on the process requirement.

* The minimum value of capacity control varies by operating conditions and models.

COMPLIANCE TO API 619

Previously, API619 was the standard for dry screw compressors exclusively, but from the 3rd edition (and moving forward) oil flooded screw compressors are also officially included. Mayekawa is able to meet the specifications required by API 619 such as cast steel casings, forged steel rotors, tilting pad thrust bearings, vibration and displacement probes, bearing temperature sensors, etc., to fit any customers' requirements.

BEARINGS

Sleeve type radial bearings and anti-friction ball thrust bearings are standard, but special material sleeve bearings and tilting pad thrust bearings are also available* to meet the customer's requirements based on gas properties and compression conditions

HIGH EFFICIENCY, HIGH PERFORMANCE

In oil-flooded screw compressors, lube oil is injected during the gas compression process to provide lubrication for the rotors and casing, minimize gas leakage, and to cool the gas. Therefore, discharge temperatures are lower than those that occur with dry screw compressors, and higher volumetric efficiency is achieved from low compression ratios to high compression ratios.

TESTS & INSPECTIONS

All MYCOM screw compressors go through Hydrostatic Test and Pneumatic Test to ensure their excellent pressure resistance and airtight sealing. Only the compressors that satisfy the performance, vibration, noise and function standard after Mechanical Running Test are shipped from the factory. Other tests, including tests for third party certifications, such as DNV, GL, and BV, can be arranged.

EXPLOSION PROOF

For capacity and control monitoring, Mayekawa provides slide valve position sensors with indicators (without indicators on GH series models). Explosion proof indicator is available as an option.

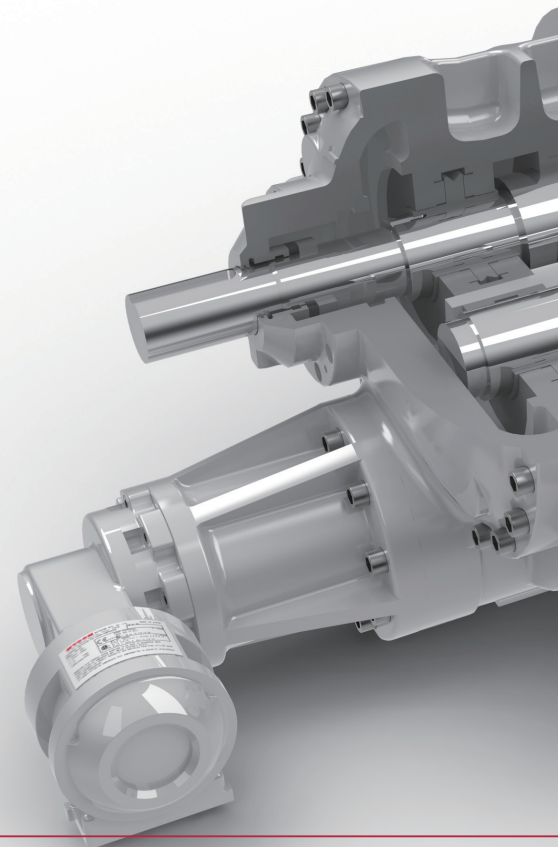

SHAFT SEALS

The oil flooded type screw compressors require only one shaft seal, unlike the dry type compressors. In order to ensure high reliability and durability under all operating conditions, various kinds of shaft seals are available. The balance type single mechanical seal is used most often but a double seal, bellows seal, gas seal, etc. are also available.

LOW NOISE, LESS VIBRATION

Unlike conventional reciprocating compressors, screw compressors have no reciprocal motion, so that the noise and vibration are far lower. Also, unlike centrifugal or dry type compressors, high rotation speeds are not required and no high frequency noise will be generated.

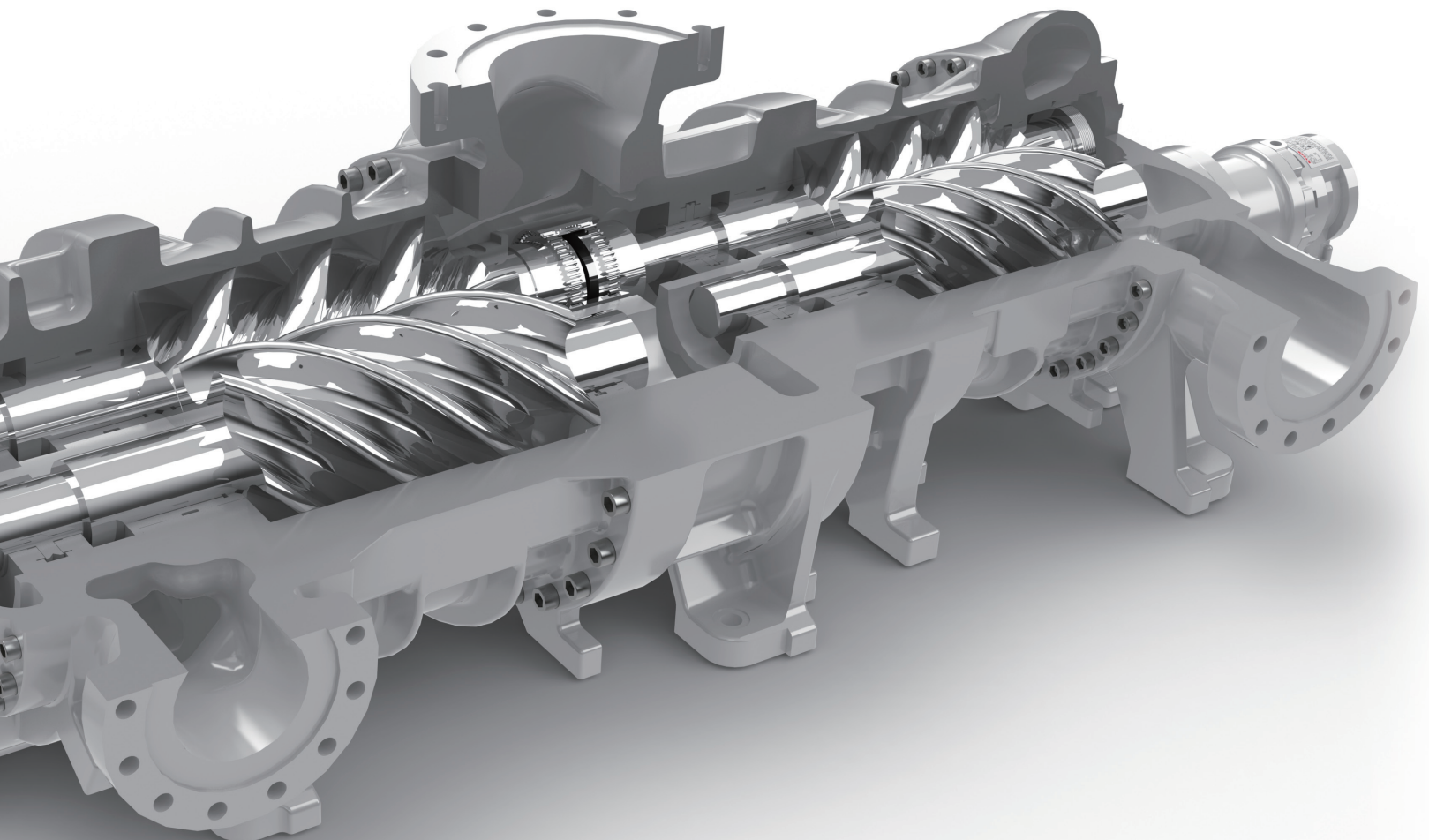

MYCOM

SCREW COMPRESSORS

Swept Volumes

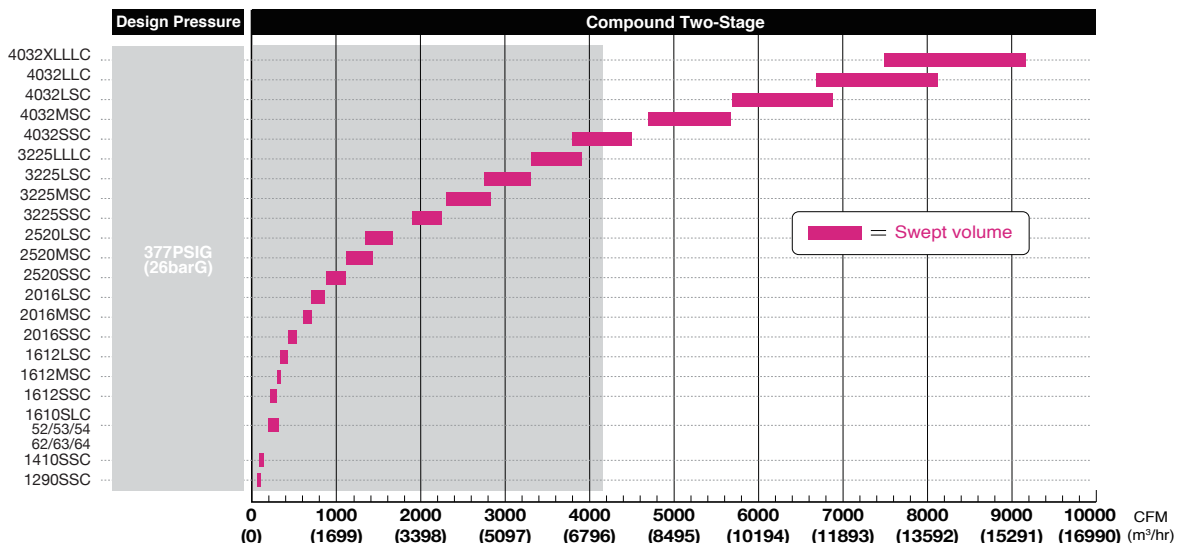
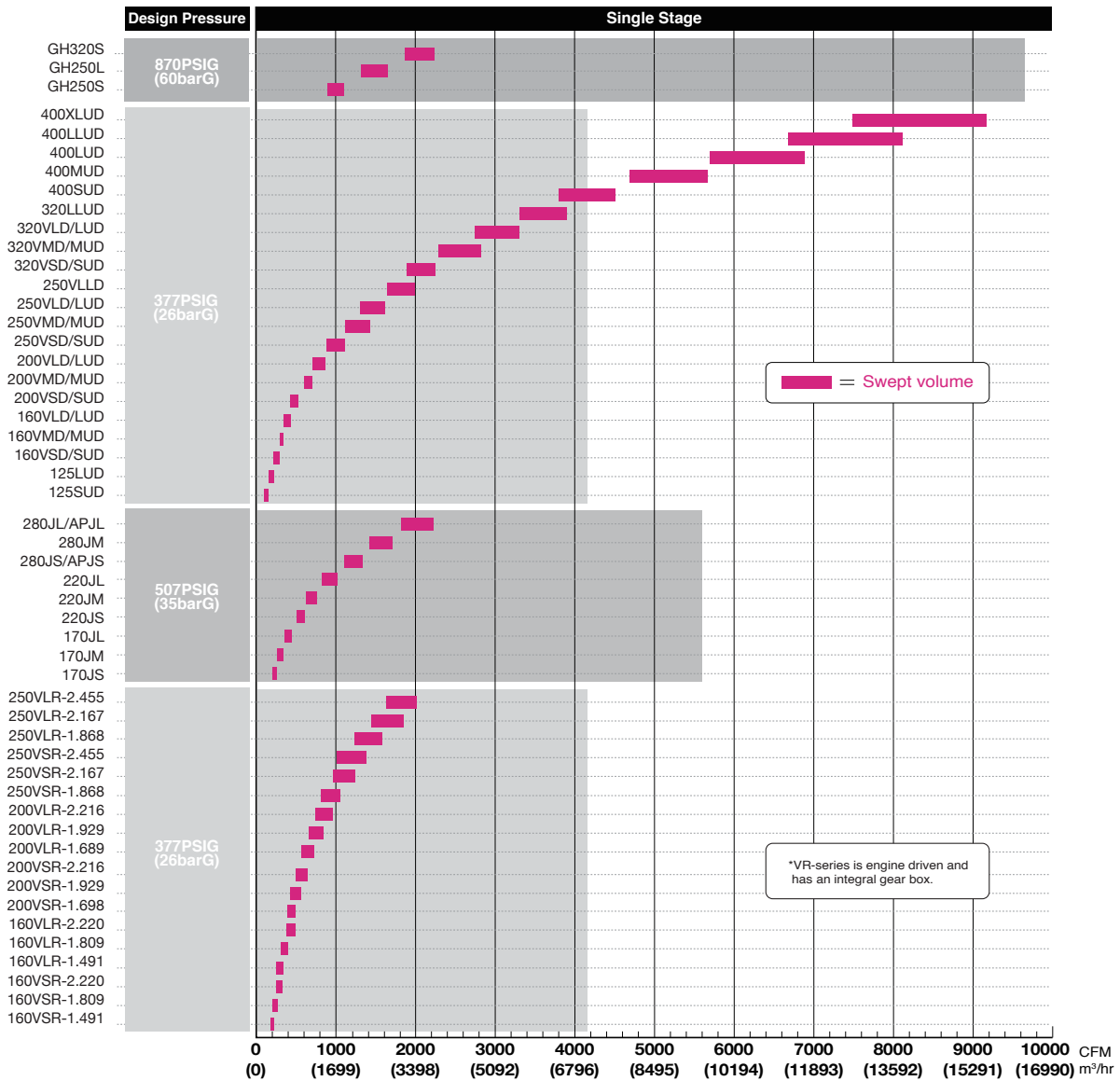

Refrigeration Capacity Reference for Commonly Used Compressors (with Propane)

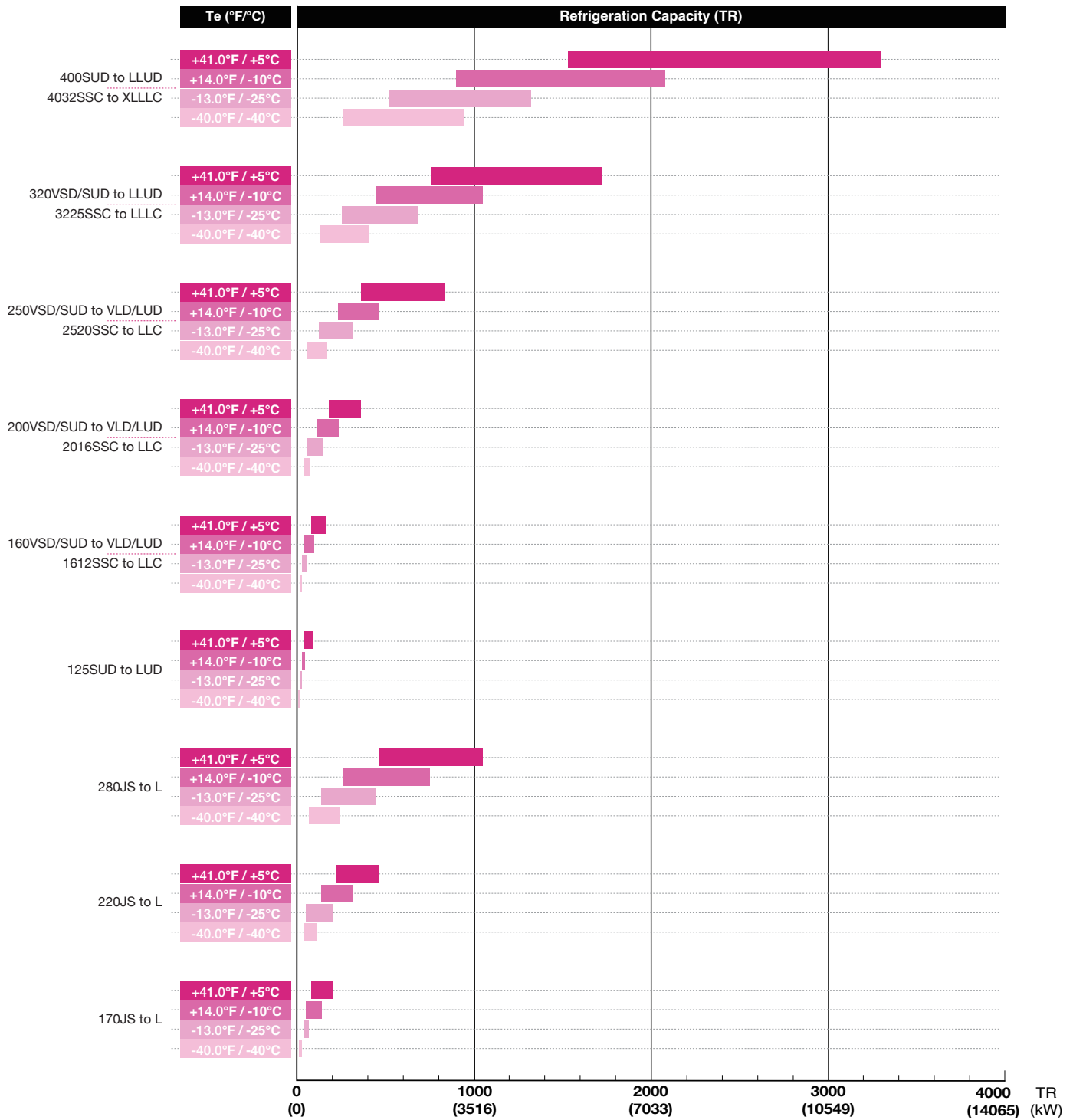

- For reference use only. Capacity is dependent on refrigerants and other details in operating conditions. Please contact Mayekawa for capacity for specific requirements.
- Compressor speed @ 2950 & 3550 rpm
- Tc=+104°F (+40°C) with and without intercooler.
- 400XL is available for applications with lower discharge pressure.

Long-seller models with cast steel casing as standard. Acclaimed 4x6 rotor lobes ensure optimal performance.

Screw Compressor [Single Stage] Open Type UD SERIES



Wide-Capacity Range

A lineup of high-capacity compressors with a displacement from 116 ~ 9182 CFM*, which is not available in the SCV series.

* With a 2 pole direct drive motor.

Operating Pressure Range

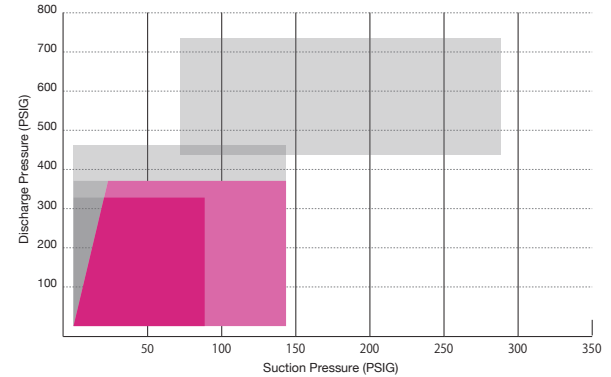

* For reference only. ** Greyed areas indicate pressure ranges of other models.

API619

Cast steel casing with ductile iron rotors (125 to 400LUD models) is the standard. Forged steel rotors, tilting pad thrust bearings and other API619 compliant options are available.

* Cast iron casings are available for 125 and 400 UD models.. Please consult Mayekawa for ductile iron casings option.

Specifications

Item	Model *1	125			160			200			250			320				400					
		SUD	LUD		SUD	MUD	LUD	SUD	MUD	LUD	SUD	MUD	LUD	SUD	MUD	LUD	LLUD	SUD	MUD	LUD	LLUD	XLUD	XXLUD *5
Working Fluid		Hydrocarbons and other gas Propane, Propylene / HFCs / Ammonia																					
Minimum rotation speed	rpm	1450*2																					
Maximum rotation speed	rpm	4500*2											3600*2										
Rotation direction		CCW, viewed from motor																					
Capacity control	%	100-10*3																					
Gas inlet port		ANSI #300 4" *4		ANSI #300 5"			ANSI #300 6"			ANSI #300 10"			ANSI #300 14"				ANSI #300 16"						
Gas outlet port		ANSI #300 3" *4		ANSI #300 3"			ANSI #300 5"			ANSI #300 6"			ANSI #300 8"				ANSI #300 12"						

* 1. Please contact us separately for 125 models with a designation ending with G (downward discharge).
 * 2. The range of rotation speed varies by operating conditions. Please refer to the ranges of use stated in the operating instructions.
 * 3. The minimum value of capacity control varies by operating conditions and models.
 * 4. MYCOM flanges for iron casing models. * 5. Please contact us for information on 400XXLUD.

Swept Volumes, Dimensions & Weight

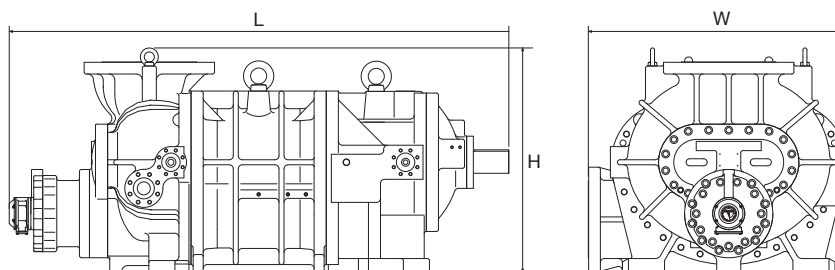

* The outer dimension drawings illustrate the model 400LUD.

	Theoretical Displacement				Dimensions			Weight	
	50Hz		60Hz		W in (mm)	L in (mm)	H in (mm)	Cast Steel lbs (kg)	Cast Iron lbs (kg)
	CFM	m ³ /h	CFM	m ³ /h					
125SUD	116	197	139	237	16 (404)	33 (846)	15 (386)	485 (220)	441 (200)
125LUD	174	295	210	356	16 (404)	36 (916)	15 (386)	529 (240)	485 (220)
160SUD	244	415	294	499	19 (470)	41 (1029)	17 (431)	782 (355)	706 (320)
160MUD	305	519	367	624	19 (470)	42 (1074)	17 (431)	882 (400)	794 (360)
160LUD	366	622	441	749	19 (470)	44 (1119)	17 (431)	970 (440)	882 (400)
200SUD	477	810	574	975	26 (657)	47 (1201)	21 (540)	1455 (660)	1323 (600)
200MUD	600	1020	718	1220	26 (657)	50 (1258)	21 (540)	1588 (720)	1433 (650)
200LUD	712	1210	859	1460	26 (657)	52 (1313)	21 (540)	1698 (770)	1544 (700)
250SUD	930	1580	1118	1900	31 (789)	55 (1397)	26 (655)	2580 (1170)	2337 (1060)
250MUD	1165	1980	1401	2380	31 (789)	58 (1469)	26 (655)	2778 (1260)	2514 (1140)
250LUD	1389	2360	1672	2840	31 (789)	61 (1537)	26 (655)	2911 (1320)	2646 (1200)
320SUD	1866	3170	2248	3820	39 (996)	71 (1798)	34 (861)	4939 (2240)	4476 (2030)
320MUD	2331	3960	2802	4760	39 (996)	74 (1886)	34 (861)	5468 (2480)	4961 (2250)
320LUD	2790	4740	3355	5700	39 (996)	78 (1973)	34 (861)	5821 (2640)	5292 (2400)
320LLUD	3295	5600	3966	6740	39 (996)	79 (2018)	34 (861)	7563 (3430)	6858 (3110)
400SUD	3814	6480	4591	7800	51 (1290)	83 (2109)	44 (1120)	11907 (5400)	11709 (5310)
400MUD	4791	8140	5768	9800	51 (1290)	90 (2275)	44 (1120)	13892 (6300)	13583 (6160)
400LUD	5709	9700	6886	11700	51 (1290)	98 (2491)	44 (1120)	15876 (7200)	15457 (7010)
400LLUD	6769	11500	8122	13800	51 (1290)	103 (2613)	44 (1120)	17750 (8050)	17221 (7810)
400XLUD	7593	12900	9182	15600	51 (1290)	107 (2716)	44 (1120)	19850 (8880)	-
400XXLUD **	-	-	-	-	-	-	-	-	-

* Please contact us separately for 125 models with a designation ending with G (downward discharge). ** Cast steel casing is not available for 250LLUD.

*** Please consult us for further details. **** Please contact us for information on 400XXLUD.

Wide-range models with standard cast iron casing. Variable Vi allows one machine to cover different pressure conditions.

Screw Compressor [Single Stage] Open Type SCV SERIES

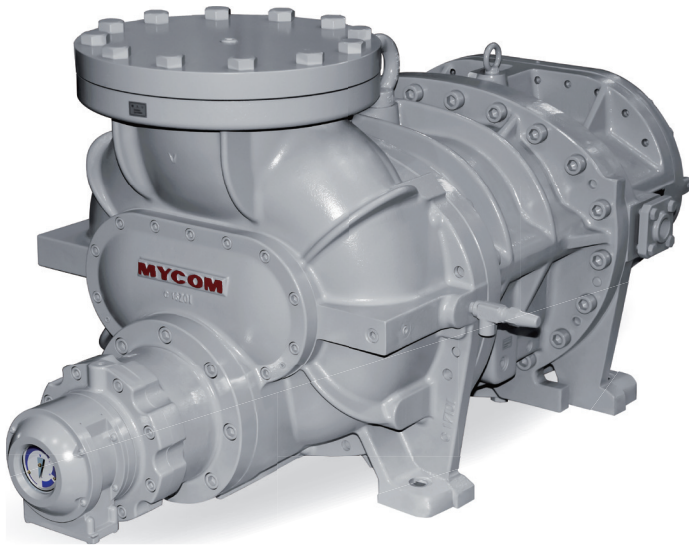

Variable Vi Mechanism (2.63-5.80 range) to Efficiently Cover Wide Temperature Range

Offers Wide Range of Capacities

Available in 13 models, the SCV series covers a wide displacement range from 244 CFM to 3355 CFM*.

* With a 2 pole direct drive motor.

Operating Pressure Range

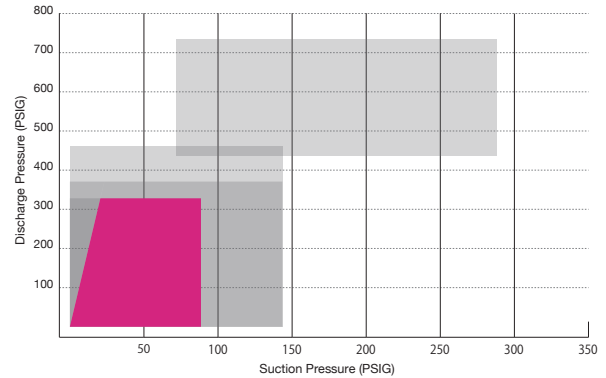

* For reference only. ** Greyed areas indicate pressure ranges of other models.

Longtime Seller

With a proven 4:6 rotor configuration, the SCV series offers optimal performance to customers.

Specifications

Item	Model	160V			200V			250V				320V			
		SD	MD	LD	SD	MD	LD	SD	MD	LD	LLD	SD	MD	LD	
Working Fluid		Hydrocarbons and other gas / Propane, Propylene / HFCs / Ammonia													
Minimum rotation speed	rpm	1450* ²													
Maximum rotation speed	rpm	4500* ²										3600* ²			
Rotation direction		CCW viewed from motor													
Capacity control	%	100-30* ³													
Gas inlet port		MYCOM 125A* ⁴			MYCOM 150A* ⁴			MYCOM 250A* ⁴				MYCOM 350A* ⁴			
Gas outlet port		MYCOM 100CD* ⁴			MYCOM 125CD* ⁴			MYCOM 150CD* ⁴				MYCOM 200CD* ⁴			

* 1. Please contact us separately for models with a designation ending with G (downward discharge).

* 2. The range of rotation speed varies by operating conditions. Please refer to the ranges of use stated in the operating instructions.

* 3. The minimum value of capacity control varies by operating conditions and models. * 4. Flanges with a designation starting with MYCOM are in-house products of MYCOM.

Swept Volumes, Dimensions & Weight

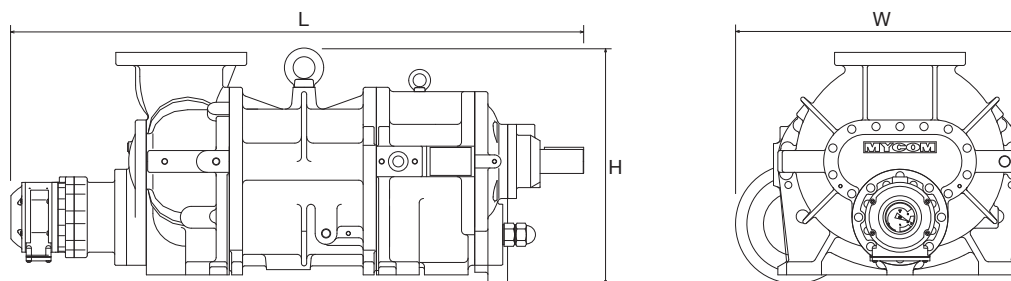

* The outer dimension drawings illustrate the model 200VLD.

	Theoretical Displacement				Dimensions			Weight lbs (kg)
	50Hz		60Hz		W	L	H	
	CFM	m ³ /h	CFM	m ³ /h	in (mm)	in (mm)	in (mm)	
160VSD	244	415	294	499	19 (470)	41 (1029)	17 (431)	816 ((370)
160VMD	305	519	367	624	19 (470)	42 (1074)	17 (431)	838 (380)
160VLD	366	622	441	749	19 (470)	44 (1119)	17 (431)	860 (390)
200VSD	477	810	574	975	26 (657)	47 (1201)	21 (540)	1389 (630)
200VMD	600	1020	718	1220	26 (657)	50 (1258)	21 (540)	1477 (670)
200VLD	712	1210	859	1460	26 (657)	52 (1313)	21 (540)	1544 (700)
250VSD	930	1580	1118	1900	31 (789)	55 (1397)	26 (655)	2558 (1160)
250VMD	1165	1980	1401	2380	31 (789)	28 (1469)	26 (655)	2690 (1220)
250VLD	1389	2360	1672	2840	31 (789)	61 (1537)	26 (655)	2867 (1300)
250VLLD	1648	2800	1984	3370	31 (789)	64 (1615)	26 (655)	3065 (1390)
320VSD	1866	3170	2248	3820	39 (996)	71 (1798)	34 (861)	5248 (2380)
320VMD	2331	3960	2802	4760	39 (996)	74 (1886)	34 (861)	5468 (2480)
320VLD	2790	4740	3355	5700	39 (996)	78 (1973)	34 (861)	5821 (2640)

* Please consult us for further details.

High-pressure models that meet API619 requirement

Screw Compressor [Single Stage] Open Type GH SERIES

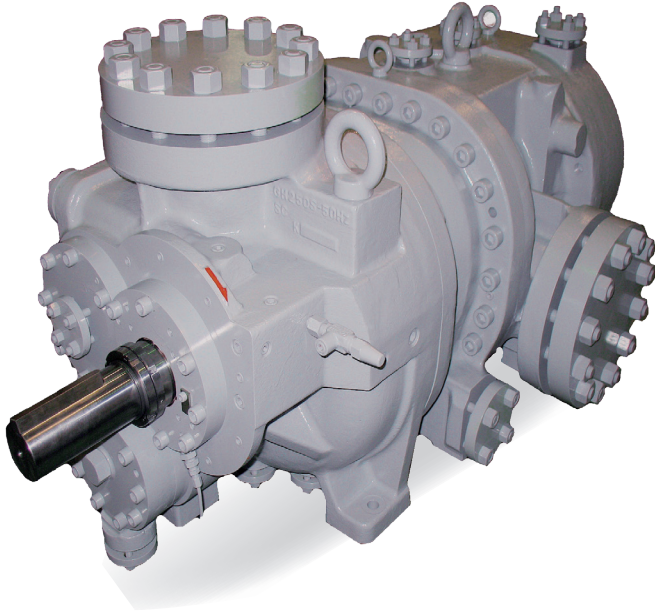

High-Pressure

The design pressure (MAWP) at 870PSI.

High Efficiency

The newly developed 5:7 rotor lobe configuration gives high rigidity, high efficiency for rigorous operating conditions.

Operating Pressure Range

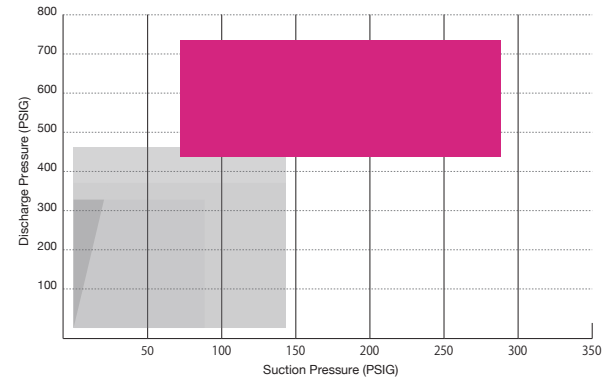

* For reference only. ** Greyed areas indicate pressure ranges of other models.

Standard API619

Cast steel casings, forged steel rotors, tilting pad thrust bearings are standard features of GH series models. Other materials are optional.

Specifications

Item	Model	GH250S	GH250L	GH320S
Working Fluid		Hydrocarbon, Helium, Hydrogen and other gases		
Minimum rotation speed	rpm	1400 *1		2950
Maximum rotation speed	rpm	4500 *1		3600
Rotation direction		CW, viewed from motor *2		
Capacity control	%	100-30		
Gas inlet port		ANSI #600 6"	ANSI #600 6"	ANSI #600 10"
Gas outlet port		ANSI #600 6"	ANSI #600 6"	ANSI #600 10"

* 1. The range of rotation speed varies by operating conditions. Please refer to the ranges of use stated in the operating instructions.

* 2. The minimum value of capacity control varies by operating conditions and models.

Swept Volumes, Dimensions & Weight

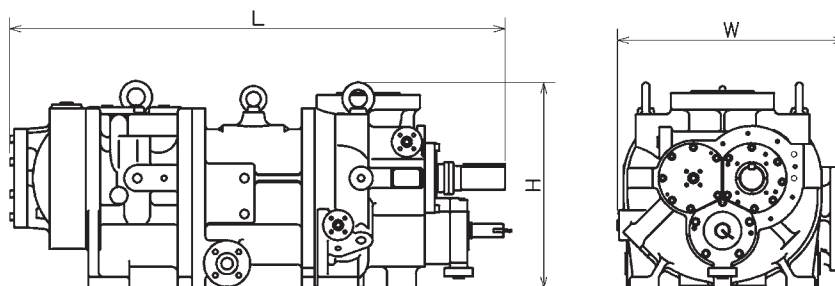

* The outer dimension drawings illustrate the model GH250L.

	Theoretical Displacement				Dimensions			Weight
	50Hz		60Hz		W	L	H	
	CFM	m ³ /h	CFM	m ³ /h	in (mm)	in (mm)	in (mm)	lbs (kg)
GH250S	912	1550	1101	1870	31 (785)	62 (1568)	27 (680)	5556 (2520)
GH250L	1383	2350	1660	2820	31 (785)	67 (1710)	27 (687)	5314 (2410)
GH320S	1890	3210	2272	3860	40 (1005)	77 (1953)	38 (970)	11025 (5000)

* Please consult us for further details.

Newly designed compressor achieving high performance:
Next-generation standard

Screw Compressor [Single Stage] Open Type J SERIES

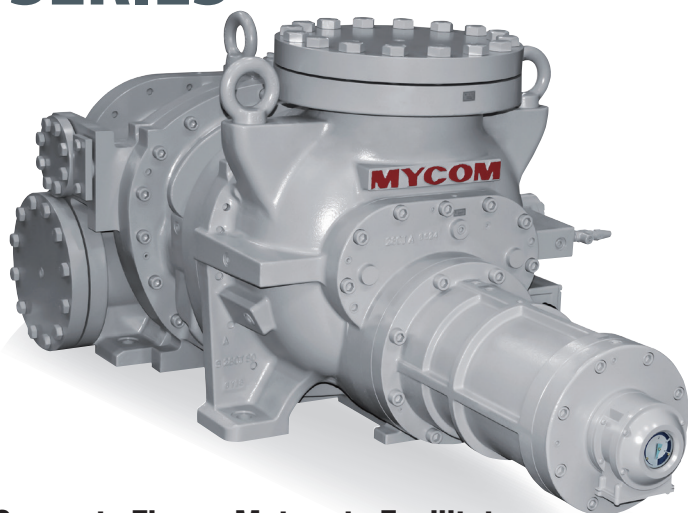

Supports Flange Motors to Facilitate Design of Packaged Systems

The built-in check valve as well as the compatibility with flange motors help reduce cost for designing packaged systems while contributing to space saving.

* Size 280 models have no built-in check valve and thus does not support flange motors.

Rich in Variation

Natural refrigerants (e.g. ammonia, CO₂, propane) and fluorocarbon refrigerants can be used. Flexible setup of applications is possible.

Specifications

Item	Model	170J			220J			280J			280APJ		
		S-V	M-V	L-V	S-V	M-V	L-V	S-V	M-V	L-V	S	M	L
Working Fluid		Propane, Propylene / HFCs / Ammonia / CO ₂ , etc.											
Minimum rotation speed	rpm	1450 *1											
Maximum rotation speed	rpm	4500 *1						3600 *1					
Rotation direction		CCW, viewed from motor											
Capacity control	%	100-25 *2						100-30 *2					
Gas inlet port		ANSI #300 5"			ANSI #300 8"			ANSI #300 12"					
Gas outlet port		ANSI #300 3"			ANSI #300 5"			ANSI #300 8"					
Flange motor connection	NEMA	44"D / 50"D			44"D / 50"D			Not compatible					
	IEC	FF500 / 600			FF500 / 600								

* 1. The range of rotation speed varies by operating conditions. Please refer to the ranges of use stated in the operating instructions.

* 2. The minimum value of capacity control varies by operating conditions and models.

Adoption of New-Type Rotor

The newly developed J-profile rotor design consisting of a 5:6 lobe configuration enables to achieving high-performance.

Low Vibration and Low Noise

The noise level has been reduced by 5 dB compared to a conventional models.

Stepless Capacity Control from 100% to 25% Range

Owing to the stepless control feature, the series optimally operates in accordance with the required load and delivers high energy-saving performance.

Automatically Variable Vi Mechanism (2.5-5.0 range) to Efficiently Cover Wide Temperature Range

*Not applicable on APJ280

Operating Pressure Range

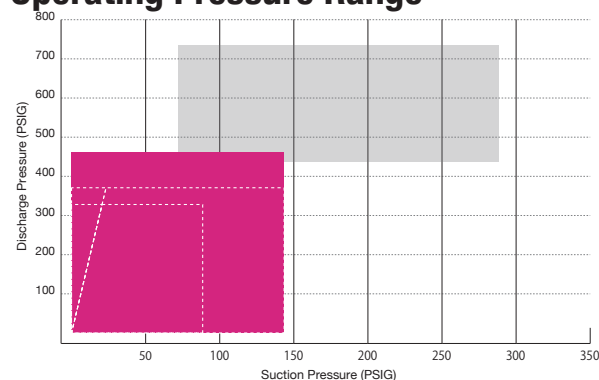

* For reference only. ** Greyed areas indicate pressure ranges of other models.

API619 Compliant Model : 280APJ

J-series offer API619 compliant models in 280 size class; 280APJ. Cast steel casings, forged steel rotors, tilting pad thrust bearings are standard options on 280APJ models.

Swept Volumes, Dimensions & Weight

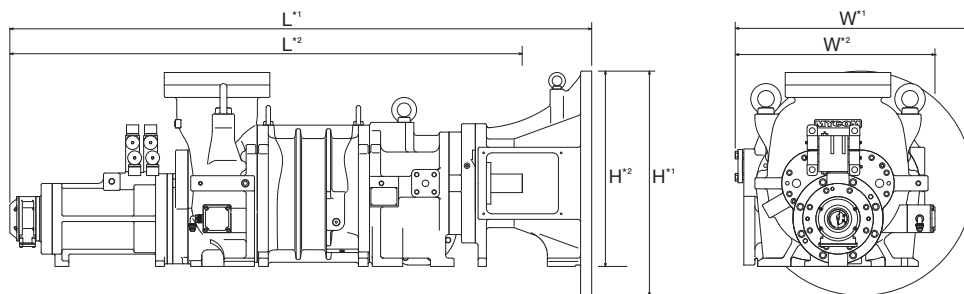

* The outer dimension drawings illustrate the model 220JL with an IEC FF600 motor spacer.

	Theoretical Displacement				Dimensions			Weight
	50Hz		60Hz		W	L	H	
	CFM	m ³ /h	CFM	m ³ /h	in (mm)	in (mm)	in (mm)	lbs (kg)
170JS	230	390	276	469	26 (669)	63 (1599)	26 (660)	1929 (875)
170JM	298	507	359	610	26 (669)	65 (1654)	26 (660)	1996 (905)
170JL	388	659	467	793	26.25 (669)	68 (1726)	26 (660)	2095 (950)
220JS	504	856	606	1030	34 (859)	76 (1935)	32 (810)	3308 (1500)
220JM	656	1114	789	1340	34 (859)	79 (2007)	32 (810)	3440 (1560)
220JL	852	1447	1025	1741	34 (859)	83 (2100)	32 (810)	3594 (1630)
280JS**	1110	1886	1335	2269	35 (896)	83 (2112)	32 (812)	5072 (2300)
280JM**	1443	2451	1736	2949	35 (896)	87 (2205)	32 (812)	5402 (2450)
280JL**	1878	3190	2260	3839	35 (896)	92 (2328)	32 (812)	5733 (2600)
280APJS**	1110	1886	1335	2269	35 (896)	83 (2112)	32 (812)	5684 (2578)
280APJM**	1443	2451	1736	2949	35 (896)	87 (2205)	32 (812)	6020 (2730)
280APJL**	1878	3190	2260	3839	35 (896)	92 (2328)	32 (812)	6458 (2929)

* Models 170-220JS/JM/JL include an IEC FF600 flange motor connection. * Models 280JS/JM/JL do not support flange motor spacers.

* Please consult us for further details.

J PROFILE ROTOR developed for higher efficiency

Mayekawa has a history of developing original rotor profiles in order to provide the best performance in given requirements. “J profile” rotors allow more proficient meshing between the lobes that give the J-series compressors superior performance in terms of efficiency and compression.



**Small compressor with high reliability
Easily integrated in packaged systems**

Screw Compressor [Single Stage] Open Type i SERIES

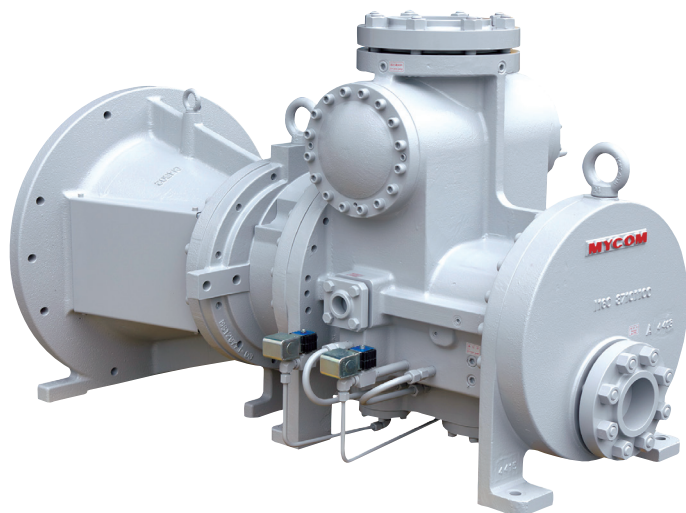

Differential Oil Feed Eliminates Need of an Oil Pump

The newly adopted ball bearings enable the i-series screw compressor delivers high performance without the need of an oil pump.

Space-Saving Design

Using a flange motor, the small-footprint compressor can be installed in a confined space.

Easily Maintainable

Designed to facilitate the replacement of consumables.

Operating Pressure Range

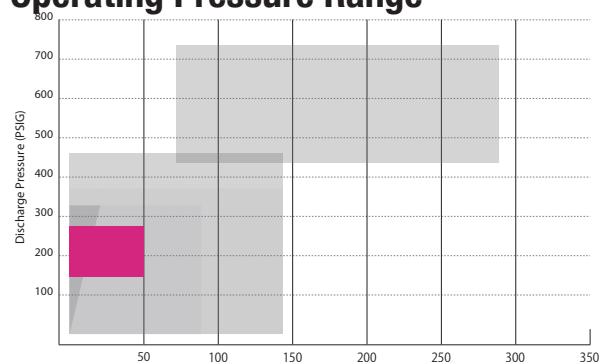

* For reference only. ** Greyed areas indicate pressure ranges of other models.

Facilitates Design of Packaged Systems

Featuring a built-in suction strainer and check valve, the i-series screw compressor supports flange motors and facilitates the design of packaged systems.

Specifications

Item		Model		125i			160i		
		S	L	S	M	L			
Working Fluid		Ammonia / HFCs							
Minimum rotation speed	rpm	2950 *1							
Maximum rotation speed	rpm	3550 *1							
Rotation direction		CW, viewed from motor							
Capacity control	%	3-step (100%, 75%, 50%) unloader *2							
Connected pipe size	Suction flange	MYCOM 100A 4"			ANSI #300 5"				
	Discharge flange	MYCOM 65ACD			ANSI #300 3"				
	Oil inlet port	Rc1/2			MYCOM 25A 1"				
	Intermediate gas	Rc3/8			Rc3/4				

* 1. The range of rotation speed varies by operating conditions. Please refer to the ranges of use stated in the operating instructions.

* 2. Numerical values are calculated values. The actual rate of change in air volume varies depending on operating conditions.

Swept Volumes, Dimensions & Weight

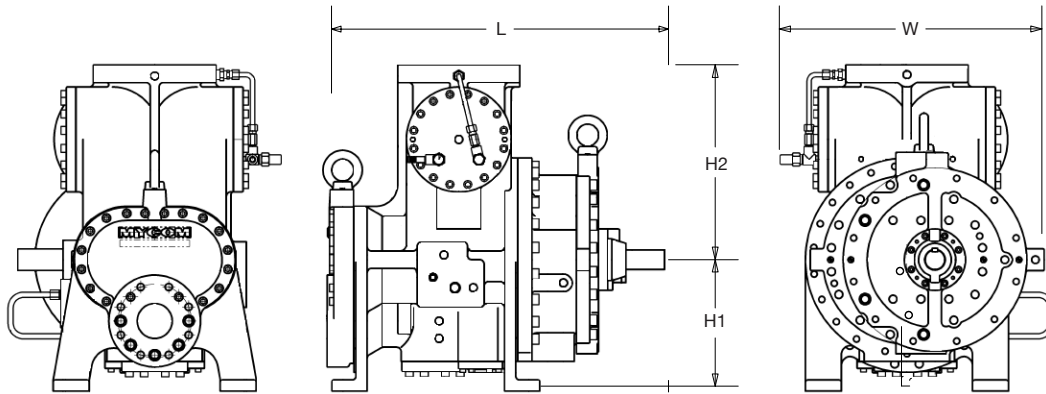

* Dimensions are for reference only. Please contact MYCOM for more detailed drawings.

	Theoretical Displacement				Dimensions				Weight
	50Hz		60Hz		W	L	H1	H2	lbs (kg)
	CFM	m ³ /h	CFM	m ³ /h	in (mm)	in (mm)	in (mm)		
i125S	116	197	139	237	19 (470)	26 (656)	11 (280)	20 (519)	728 (330)
i125L	174	296	210	356	19 (470)	29 (726)	11 (280)	20 (519)	772 (350)
i160S	244	415	294	499	24 (619)	30 (773)	12 (311)	17 (434)	1080 (490)
i160M	305	519	367	624	24 (619)	32 (818)	12 (311)	17 (434)	1168 (530)
i160L	366	622	441	749	24 (619)	34 (863)	12 (311)	17 (434)	1257 (570)

* Please consult us for further details.

Designed specifically for engine driven field gas application with integral gear box

Screw Compressor [Single Stage] Open Type VR SERIES



Gear Change, Regardless of Engine Speed

With multiple gear ratios, there is more capacity available with a simple gear change regardless of your engine speed.

Standard Features That Are Perfect for Natural Gas Field

- ASTM A48M (equiv) -45B cast iron casing, MAWP 350psig
- ASTM A-536 80-55-06 (equiv) ductile iron rotors
- single oil flooded mechanical seal engine or motor driven with gears for more capacity
- viton O-rings
- 10~100% hydraulically actuated slide valve
- position indicator and potentiometer
- hydrodynamic API619 / NACE compliant journal bearings
- dynamically balanced integral gear with internal lube system
- manually adjustable volume ratio 2.63~5.8 operating suction pressure to 85psig

Optional Features

- integral oil pump
- manual slide valve adjuster
- double balanced, dual, dry mechanical seals

Specifications

Item	Model	160VR		200VR		250VR	
		S	L	S	L	S	L
Working Fluid		Natural Gas / Other Gas					
Minimum rotation speed	rpm	973 *1		859 *1		776 *1	
Maximum rotation speed	rpm	3018 *1		2664 *1		2409 *1	
Rotation direction		CW, viewed from motor					
Capacity control	%	100-30 *2					
Gas inlet adaptor flange		ANSI #300 5"		ANSI #300 6"		ANSI #300 10"	
Gas outlet bearing head		ANSI #300 3"		ANSI #300 5"		ANSI #300 6"	

* 1. The rotation speeds shown here are that of commonly used VR models. Please consult us for details.

* 2. The minimum value of capacity control varies by operating conditions and models.

Swept Volumes, Dimensions & Weight

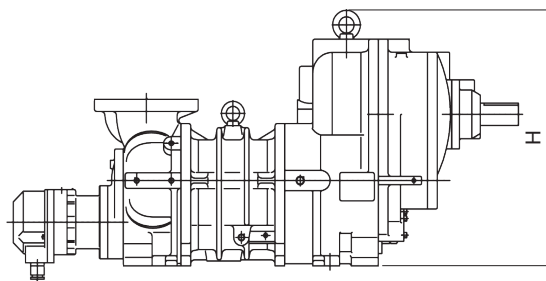
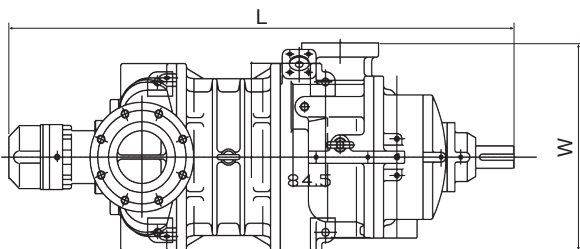

	Theoretical Displacement		Dimensions		
	with engine @1800 rpm		W	L	H
	CFM	m ³ /h	in (mm)	in (mm)	in (mm)
160VSR-1.491	222	378	20 (511)	48 (1225)	22 (557)
160VSR-1.809	270	458	20 (511)	48 (1225)	22 (557)
160VSR-2.220	331	562	20 (511)	48 (1225)	22 (557)
160VLR-1.491	333	566	20 (511)	52 (1315)	22 (557)
160VLR-1.809	404	687	20 (511)	52 (1315)	22 (557)
160VLR-2.220	496	843	20 (511)	52 (1315)	22 (557)
200VSR-1.689	491	835	25 (631)	57 (1454)	29 (746)
200VSR-1.929	562	954	25 (631)	57 (1454)	29 (746)
200VSR-2.216	647	1100	25 (631)	57 (1454)	29 (746)
200VLR-1.689	736	1250	25 (631)	62 (1566)	29 (746)
200VLR-1.929	842	1430	25 (631)	62 (1566)	29 (746)
200VLR-2.216	965	1640	25 (631)	62 (1566)	29 (746)
250VSR-1.868	1060	1800	31 (789)	71 (1796)	36 (924)
250VSR-2.167	1220	2080	31 (789)	71 (1796)	36 (924)
250VSR-2.455	1390	2360	31 (789)	71 (1796)	36 (924)
250VLR-1.868	1580	2690	31 (789)	76 (1937)	36 (924)
250VLR-2.167	1840	3130	31 (789)	76 (1937)	36 (924)
250VLR-2.455	2080	3540	31 (789)	76 (1937)	36 (924)

* Please consult us for the weight information and other details.

** Please note some VR models are no longer in production. Consult us for further details and alternative models.

Two-stage compressors compounded in one casing for single driver and single lube system to cut down space requirement and cost.

Screw Compressor [Two Stage] Open Type C SERIES

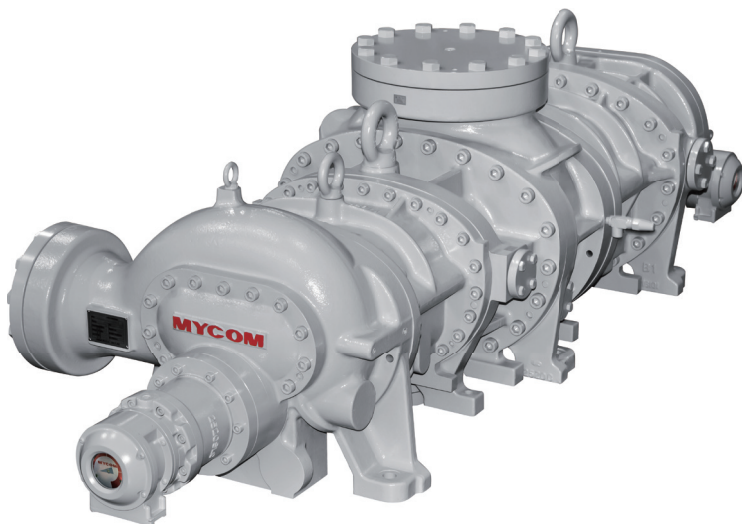

Efficient Two-Stage Compression Done in Single Compressor for High Compression Ratio

Wide-Range Lineup

Wide range of models* with a variety of high-stage x booster stage combinations is available to cover swept volume from 216 CFM to 9182 CFM**.

*The models (rotor combinations) shown herein are only those that are typically used. Contact us for other models and rotor combinations.

**With a 2 pole direct drive motor.

Operating Pressure Range

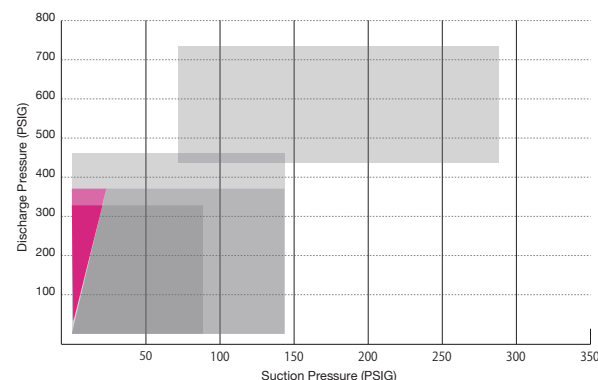

* For reference only.

API619

Cast steel casings, forged steel rotors, tilting pad thrust bearings and other API619 compliant options are available.

Specifications

Items	Models	1610SLC-52 ^{*1}		1612LSC		2016LSC		2520LSC		3225LSC		4032LSC	
		Low Stage	High Stage	Low Stage	High Stage	Low Stage	High Stage	Low Stage	High Stage	Low Stage	High Stage	Low Stage	High Stage
Working Fluid		Hydrocarbons and other gas / Propane, Propylene / HFCs / Ammonia											
Minimum rotation speed	rpm	1450 ^{*2}											
Maximum rotation speed	rpm	1750 ^{*2}	4500 ^{*2}	4000 ^{*2}	3600 ^{*2}								
Rotation direction		CW when viewed from motor side		CCW, viewed from motor									
Capacity control	%	100-30 ^{*3}											
Gas inlet port		MYCOM 125A ^{*4}	MYCOM 125A ^{*4}	JIS20K 150A	JIS20K 250A	JIS20K 350A	ANSI#300 16"						
Gas outlet port		JIS20K 50A	MYCOM 65A ^{*4}	JIS20K 80A	JIS20K 100A	JIS20K 150A	ANSI#300 8"						

* 1. The model 1610SLC-52 includes an internal step-up gear.

* 2. The range of rotation speed varies by operating conditions. Please refer to the ranges of use stated in the operating instructions.

* 3. The minimum value of capacity control varies by operating conditions and models.

* 4. Flanges with a designation starting with MYCOM are in-house products of MYCOM.

Swept Volumes, Dimensions & Weight

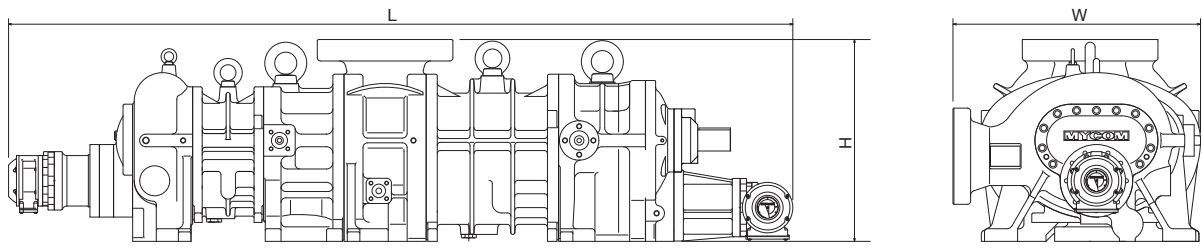

* 1. Dimensions of the model 1610SLC-52 include an internal step-up gear.
 * The outer dimension drawings illustrate the model 2520LSC.

	Theoretical Displacement				Dimension			Weight	
	50Hz		60Hz		W in (mm)	L in (mm)	H in (mm)	Cast Steel	Cast Iron
	CFM	m ³ /h	CFM	m ³ /h				lbs (kg)	lbs (kg)
1612SSC	244	415	294	499	20 (511)	48 (1231)	19 (493)	1014 (460)	926 (420)
1612MSC	305	519	367	624	20 (511)	50 (1276)	19 (493)	1125 (510)	1014 (460)
1612LSC	366	622	441	479	20 (511)	52 (1321)	19 (493)	1213 (550)	1103 (500)
2016SSC	477	810	574	975	26 (657)	68 (1726)	20 (513)	2624 (1100)	2205 (1000)
2016MSC	600	1020	718	1220	26 (657)	70 (1783)	20 (513)	2558 (1160)	2315 (1050)
2016LSC	712	1210	859	1460	26 (657)	72 (1838)	20 (513)	2668 (1210)	2426 (1100)
2520SSC	930	1580	1118	1900	31 (785)	92 (2347)	25 (640)	4631 (2100)	4212 (1910)
2520MSC	1165	1980	1401	2380	31 (785)	95 (2419)	25 (640)	4829 (2190)	4388 (1990)
2520LSC	1389	2360	1672	2840	31 (785)	98 (2487)	25 (640)	4983 (2260)	4520 (2050)
3225SSC	1866	3170	2248	3820	37 (945)	97 (2456)	33 (832)	7321 (3320)	6659 (3020)
3225MSC	2331	3960	2802	4760	37 (945)	103 (2628)	33 (832)	7673 (3480)	6968 (3160)
3225LSC	2790	4740	3355	5700	37 (945)	107 (2715)	33 (832)	8026 (3640)	7299 (3310)
3225LLC	3296	5600	3967	6740	37 (945)	116 (2952)	33 (832)	10077 (4570)	9151 (4150)
4032SSC	3814	6480	4591	7800	51 (1305)	130 (3297)	47 (1199)	17464 (7920)	16979 (7700)
4032MSC	4791	8140	5768	9800	51 (1305)	138 (3507)	47 (1199)	19404 (8800)	18853 (8550)
4032LSC	5709	9700	6886	11700	51 (1305)	142 (3615)	47 (1199)	21234 (9630)	20617 (9350)
4032LLLC	6769	11500	8122	13800	51 (1305)	158 (4009)	47 (1199)	23924 (10850)	23153 (10500)
4032XLLLC	7593	12900	9182	15600	51 (1305)	167 (4239)	47 (1199)	27166 (12320)	-

MYCOM Screw Compressors Features

SPECIAL SEALS

Various kinds of shaft seals are available. Double seal, bellows seal, gas seal, and seals for Plan-52, 53, 72 and 74 that are specified in API 682 are also available options.

Available models : Ask Mayekawa.

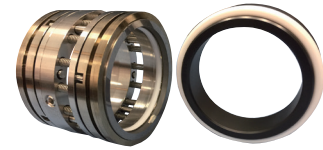

EXPLOSION PROOF INDICATORS

The slide valve position indicator installed on the compressors meet the criteria of several certifications that are trusted worldwide and required in some of the toughest applications in industry. IEC, ATEX, cCSAus or TIIS compliant indicators are offered options for explosion proof.

Available models : All models. *GH series models provide slide valve position sensors.



TILTING PAD THRUST BEARINGS

GH series models come equipped with tilting pad thrust bearings as a standard feature. Tilting pad thrust bearings are suitable under severe loads, with process gas such as H₂ rich gas, and/or per API requirements.

Available models : Standard on GH models. Ask Mayekawa about other models.

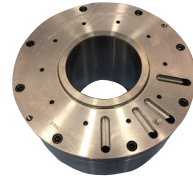

RADIAL BEARINGS

Sleeve type hydrodynamic radial bearings, as specified in API standards, are the standard feature of MYCOM screw compressors to provide long operational life as well as to apply to severe conditions in which rolling element bearings can hardly withstand. Special design bearings using non-standard materials, such as Babbitt metal, are also offered according to process conditions.

Available models : Standard on all models.



CAPACITY CONTROL by SLIDE VALVE

Capacity control is accomplished by a slide valve which moves parallel to the rotor axis and changes the area of the opening in the bottom of the rotor casing. This, in effect, lengthens or shortens the region of compression of the rotor and further acts to return gas to the suction side, while bypassing compressed gas. Appropriate control signals can be used to operate the slide valve hydraulically activated by/with the compressor lube oil system or a separate oil system.

Available models : Standard on all models.

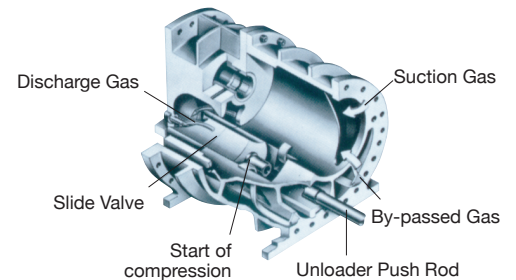

Slide Valve Mechanism & Capacity Control

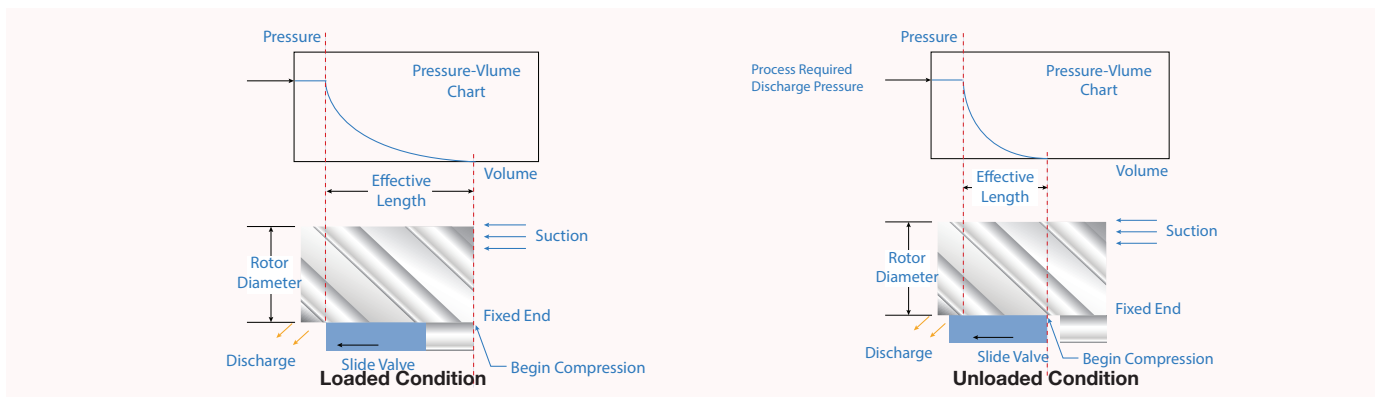

Information herein are for reference only. Subject to change without notice.